

MODEL YSE

3. GENERAL DESCRIPTION

Each of Yanmar diesel engines, models YSE8 and YSE12, comes equipped with clutch reduction gear, which together with a flywheel is totally enclosed in the flywheel housing and the clutch housing. The propeller shaft is run from the flywheel side.

The starter for electrical starting is directly mounted to the flywheel housing to drive the ring gear of the flywheel. For chain starting, the power take-off shaft is chain-connected to the starting shaft located immediately above the cylinder. The engine is started by clockwise rotation on the stern side and by counter-clockwise rotation on the bow side.

3.1 Construction

Part	Description & Specifications
1. Cyl. body	Monoblock casting of water jacket, crankcase and oil pan.
2. Cyl. liner	Wet type made of special cast iron and coated with special anticorrosive paint.
3. Main bearing	Side cover side: precision kelmet metal with thin back metal. Flywheel side: Thick metal.
4. Cyl. head	Gasket type, part of monoblock including valve guides.
5. Intake/exhaust valve	Mushroom type.
6. Intake pipe	Intake inertia type made of steel.
7. Exhaust silencer	Round, expansion type, or water injection type.
8. Valve drive system	Tappet & valve push rod type. Parabolic suction/exhaust cam with approach ramp.
9. Crankshaft	Stamp forged, with induction hardened journal, pin and oil seal portions.
10. Flywheel	Mounted to clutch, enclosed in flywheel housing.
11. Piston	Made of aluminum alloy, oval shaped.
12. Piston rings	Three compression rings, one oil scraper ring.
13. Piston pin	Float type.

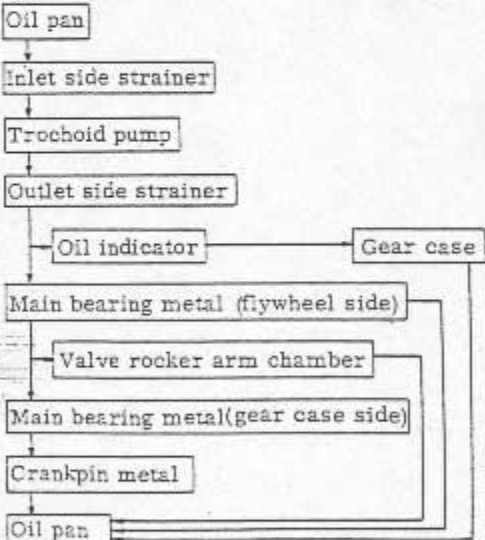
Part	Description & Specifications
14. Connecting rod	I-section, stamp forged.
15. Crankpin metal	Drum type
16. Lube oil pump	Trochoid pump, driven by camshaft.
17. Lube oil strainers	Inlet side: perforated steel type. Outlet side: auto-clean type, full-flow passing type.
18. Indicators	Electric starting: hydraulic lamp Manual starting: oil light
19. Lube oil circulation chart	 <pre> graph TD OP1[Oil pan] --> IS[Inlet side strainer] IS --> TP[Trochoid pump] TP --> OS[Outlet side strainer] OS --> OI[Oil indicator] OI --> GC[Gear case] GC --> MB1[Main bearing metal flywheel side] MB1 --> VRC[Valve rocker arm chamber] VRC --> MB2[Main bearing metal gear case side] MB2 --> CP[Crankpin metal] CP --> OP2[Oil pan] </pre>
20. Cooling water pump	Rotary type (belt-driven from power take-off shaft)
21. Fuel injection pump	Yanmar-Dickel type pump
22. Fuel injection nozzle	Pintle nozzle
23. Fuel strainer	Filter paper
24. Fuel tank	Steel plate
25. Governor	Centrifugal, all-speed type

Part	Description & Specifications
26. Governor remote control device	Remote control wire, steel lever
27. Decompression remote control	Remote control wire, steel lever
28. Electric starting device	Starter (ring gear type) Output: 1.0 KW at 12 V (nominal) Battery: 40-70 AH ←
29. Manual starting device	Speed-up chain (on stern or bow side) Speed-up ratio: 2.07 (YSE8), 2.91 (YSE12)
30. Reversing clutch	Wet type single plate disc clutch
31. Reduction gear	Constant mesh spur gear type Reduction ratio: 2 : 1, 3 : 1
32. Power take-off shaft pulley	Spur gear-driven from crank gear with pulleys for alternator and for cooling water pump.

3.2 Power Take-off Shaft Pulleys

The outside pulley is for the alternator and the inside pulley for the cooling water. If the alternator is not attached, the outside pulley can be used as desired to drive a bilge pump, winch, etc.

(Remark) The flexible mounting being on engine, not using P.T.O. shaft.

Model	YSE8	YSE12
PTO shaft rotation speed/engine speed	4100/3200 rpm	3380/3000 rpm
Outside diameter of pulley	90 mm	110 mm
V belts	Single HM type	Single HM type
PTO max. permissible output power	1-1.5/3200 HP/rpm	2-3/3000 HP/rpm

4. PERIODICAL MAINTENANCE

No.	Item	Checkpoints	Hours of operation			
			Every day	Every 100 hours	Every 250 hours	Every 500 hours
1	Fuel Oil	1. Check fuel oil level, and supply fuel, if necessary.	⊙			
		2. Discharge drainage from the fuel tank.	⊙			
		3. Clean fuel strainers.		⊙		
		4. Renew the fuel strainer filter elements.				⊙
2	Lube. Oil	1. Check lube oil levels in crankcase and reduction gear case, and supply lube oil, if necessary.	⊙			
		2. Lubricate the starting shaft, chain, and other parts.	⊙			
		3. Turn the lube oil strainer handles.	⊙			
		4. Overhaul the lube oil strainers.		⊙		
		5. Renew crankcase lube oil.		⊙		
		6. Renew clutch case lube oil.			⊙	
3	Cooling Water	1. Discharge cooling water after operation in cold season.	⊙			
		2. Check the recirculated condition of cooling water.	⊙			
4	Fuel Injection Pump & Valve	1. Check fuel injection (injection noise).	⊙			
		2. Adjust the governor.			⊙	
		3. Check fuel injection timing.				⊙
		4. Clean the nozzle.				⊙
5	Cylinder Head	1. Retighten the cylinder head bolts.		⊙		
		2. Adjust the intake/exhaust valve clearance.			⊙	
		3. Clean the internal surfaces of combustion chamber.				⊙
		4. Clean the pre-combustion chamber.				⊙
		5. Check the intake/exhaust valve seat.				⊙
		6. Check valve rocker arm and valve guides.				⊙
6	Breather, Belt, Anticorrosive Zinc, Piston & Ring	1. Wash the breather valve.		⊙		
		2. Check the belt tensions (cooling water pump, generator).		⊙		
		3. Renew the anticorrosive zinc.				⊙
		4. Check the piston and the ring.				⊙

5. FUEL AND LUBRICATING OILS

To the engine, fuel oil is food and lubricating oil is blood. Mis-handling might cause unexpected engine trouble. The efficiency of the Yanmar engine will depend upon strict adherence to these instructions and recommendations.
It is the salesman's or serviceman's duty and mission to urge the user to follow them.

5.1 Fuel Oils

5.1.1 Property requirements

(1) High cetane rating

Poor ignitability of fuel oil results in a ignition lag, causing difficult starting or knocking.

(2) Low sulphur content

Sulphur contained in fuel oil when burned is combined with water to produce sulphuric acid which corrodes metallic parts.

(3) No dust or moisture content

Dust and moisture contained in fuel oil can cause faster wear or sticking of the plunger of fuel injection pump and injection nozzle.

(4) Appropriate viscosity

Fuel viscosity has a relation to the condition of injection. It should be such that the plunger and the nozzle valve will be properly lubricated.

5.1.2 Recommended brands

Supplier	Brand
SHELL	Shell Diesoline (or local equivalent)
CALTEX	Caltex Diesel Oil
MOBIL	Mobil Diesel Oil
ESSO	Esso Diesel Oil
B.P. (British Petroleum)	B.P. Diesel Oil

5.2 Lubricating Oils

5.2.1 Functions

- (1) Lubrication--reduces friction and wear on sliding surfaces.
- (2) Cooling--carries away combustion and friction heat.

- (3) Air-tightening--keeps the cylinder air-tight, prevents escape of compressed air and operating gas.
- (4) Cleaning--carries away carbon (combustion product) and internal dust.
- (5) Rust prevention--keeps parts from rust.

Today, improved engines call for high-quality lubricating oils. Oil companies are now using a number of additives to improve the properties of their lubricating oils.

5.2.2 Classification by viscosity

Lube oil viscosity should be so selected as to suit the ambient temperature.

SAE-Viscosity Table

	SAE No.	0°F (-17.8°C)		110°F (98.9°C)	
		Saybolt universal viscosity, sec.	Kinematic viscosity, CST	Saybolt universal viscosity, sec.	Kinematic viscosity, CST
below 10°C	5W	below 4,000	below 869	-	-
	10W	6,000a-12,000	1,303a-2,606	-	-
	20W	12,000b-48,000	2,606b-10,423	-	-
10 -20°C	20	-	-	45-58	5.73-9.62
	30	-	-	58-70	9.62-12.93
over 30°C	40	-	-	70-85	12.92-16.77
	50	-	-	85-110	16.77-22.68

Yanmar YSE manual

Blank Page

6. TROUBLESHOOTING

The best engine will come to malfunction if not properly handled day after day or after a prolonged period of service.

Locating the trouble is the first consideration. Pinpointing the trouble cause is to be done next. Then comes a proper remedy therefore. If careless handling is the case, the operator may be instructed not to cause the same trouble.

The following lists the troubles, check points, possible causes, and remedies.

6.1 Engine Does Not Start

Check point	Possible cause	Remedy	Ref. page
1. Intake/exhaust valve	1. No valve clearance.	Adjust to 0.2 mm.	39
	2. Carbon or wear on valve seat.	Fit valve with quick successive movements.	25
	3. Worn valve guide.	Renew cylinder head.	24
	4. Intake/exhaust valve stuck.	Clean or renew.	
2. Fuel injection nozzle	1. Loose or unsymmetrically tightened nozzle guard.	Retighten.	
	2. Faulty or lost packing.	Repair or renew.	
3. Cylinder liner & piston	1. Unsuitable lube oil.	Change oil.	8
	2. Gasoline overcharged at start-up.		
	3. Stuck or worn piston ring.	Renew.	27
	4. Seized or worn piston and cylinder liner.	Renew.	27 30
4. Gasket	1. Gasket damaged (loose or unsymmetrically tightened head).	Renew or retighten	
5. Fuel oil	1. Fuel failure.	Supply fuel.	
	2. Tank cock in closed position.	Open cock.	21
6. Fuel injection pump	1. Air in pump.	Purge.	
	2. Dirty, scratched or worn delivery valve.	Clean or renew.	
	3. Dirty, scratched or worn regulator needle.	Clean or renew.	18
	4. Stuck or worn plunger.	Clean or renew.	18

Check point	Possible cause	Remedy	Ref. page
7. Fuel injection nozzle	1. Stuck or worn nozzle.	Clean or renew.	19
	2. High or low injection pressure.	Adjust to 160 kg/cm ² .	20
8. Main bearing	1. Stuck or seized.	Clean or renew.	33
9. Crankpin metal	1. Stuck or seized.	Clean or renew.	26
10. Starter operation	1. Battery discharge.	Recharge up to 1.26 (S.G.) at 20°C.	
	2. Key switch fault.	Renew.	
	3. Magnet switch fault.	Correct or renew.	
	4. Motor brush fault.	Renew.	35
	5. Motor unit fault.	Renew.	
11. Battery	1. Battery discharge.	Recharge up to 1.26 (S.G.) at 20°C.	
	2. Voltage drop (under no load).	Renew if below 12V.	
12. Governor lever	1. Not properly adjusted.	Readjust.	38

6.2 Difficult Start-up

Check point	Possible cause	Remedy	Ref. page
1. Temperature	1. Low.	Select suitable lube oil. Use start-up accelerator.	
2. Fuel oil	1. Unsuitable quality.	Change fuel oil	7
3. Injection	1. Stuck or worn nozzle valve.	Clean or renew.	19
	2. Low injection pressure.	Adjust to 160 kg/cm ² .	20
	3. Worn plunger.	Renew.	18
4. Intake/exhaust valve	1. Misadjusted.	Readjust.	39
5. Compression			
6. Electric equipment			35
7. Heavy manual turning	1. Stuck or seized piston, liner.	Correct or renew.	26 30
	2. Stuck or seized main bearing metal.	Correct or renew.	33
	3. Stuck or seized crankpin metal.	Correct or renew.	26
	4. Unsuitable lube oil.	Change oil.	5

6.3 Bad Exhaust Color

Check point	Possible cause	Remedy	Ref. page
1. Operating conditions	1. Overloaded operation.	Reduce load.	
2. Output decrease			13
3. Fuel oil	1. Unsuitable quality.	Change fuel oil.	7
4. Injection	1. Stuck or worn nozzle.	Correct or renew.	19
	2. Low injection pressure.	Adjust to 160 kg/cm ² .	20
5. Injection timing	1. Injection lag.	Set to 10 ± 2° before T.D.C., listening to injection noise.	40
6. Carbon deposit (Sticky)	1. Stuck or worn piston ring or oil ring.	Correct or renew.	27
	2. Worn cylinder liner or piston. (Burning oil)	Renew.	27 30

6.4 Momentary High-speed Revolution

Check point	Possible cause	Remedy	Ref. page
1. Regulator handle	1. Sudden operation.	Do not move it suddenly.	
2. Governor system	1. Misadjusted lever.	Readjust.	36
	2. Stuck regulator spindle.	Clean and correct.	

6.5 Hunting

Check point	Possible cause	Remedy	Ref. page
1. Governor system	1. Misadjusted lever.	Readjust.	36
	2. Stuck regulator spindle.	Clean and correct.	
	3. Malfunction of No. 1 lever shaft.	Correct.	
2. Injection	1. Stuck or worn nozzle.	Correct or renew.	
	2. High or low pressure.	Adjust to 160 kg/cm ² .	20
3. Fuel oil	1. Inferior quality.	Change fuel oil.	✓
4. Injection timing	1. Injection advance or lag.	Set to 10 ± 2° before T.D.C., listening to injection noise.	40
5. Crankshaft: side gap	1. Large gap. (worn main bearing)	Renew.	33

6.6 Output Decrease

Check point	Possible cause	Remedy	Ref. page
1. Compression			
2. Intake/exhaust valve	1. Over/under clearance.	Adjust to 0.2 mm.	39
3. Injection	1. Stuck or worn nozzle.	Correct or renew.	19
	2. Pressure drop.	Adjust to 160 kg/cm ² .	20
	3. Worn plunger.	Renew.	18
	4. Scratched or worn delivery valve.	Correct or renew.	18
	5. Misadjusted governor lever.	Readjust.	38
4. Fuel oil	1. Unsuitable quality.	Change fuel oil.	7
5. Combustion chamber	1. Carbon deposit.	Remove.	
6. Moving parts	1. Stuck or seized cylinder liner and piston.	Correct or renew.	27 30
	2. Stuck or seized crankpin metal.	Correct or renew.	26
	3. Stuck or seized main bearing metal.	Correct or renew.	32
	4. Stuck or seized piston pin and pin metal.	Correct or renew.	27

6.7 Knocking during Operation

Check point	Possible cause	Remedy	Ref. page
1. Tightening parts	1. Loose end nut.	Retighten.	
	2. Loose connecting rod bolts and nuts.	Retighten.	
	3. Other tightening parts loose.	Retighten.	
2. Moving parts	1. Worn or seized crankpin metal.	Renew.	26
	2. Worn or seized main bearing metal.	Renew.	32
	3. Worn or seized piston pin and pin metal.	Renew.	27
3. Intake/exhaust valve	1. Large clearance.	Adjust to 0.2 mm.	39

Check point	Possible cause	Remedy	Ref. page
4. Fuel oil.	1. Unsuitable quality.	Change fuel oil.	7
5. Injection.	1. Stuck or worn nozzle.	Correct or renew.	19
	2. High or low pressure.	Adjust to 160 kg/cm ² .	20

6.8 Sudden Engine Stop

Check point	Possible cause	Remedy	Ref. page
1. Heavy manual turning.	1. Seized main bearing metal.	Renew.	32
	2. Seized crankpin metal.	Renew.	26
	3. Seized piston and cylinder liner.	Renew.	27 30
2. Injection			
3. Compression.			
4. Fuel oil.	1. Fuel failure.	Supply fuel oil.	
	2. Unsuitable quality.	Change fuel oil.	
5. Load.	1. Overload.	Reduce load.	

6.9 Lube Oil Leak

Check point	Possible cause	Remedy	Ref. page
1. Contact surfaces of parts.	1. Loose bolts and nuts.	Retighten.	
	2. Scratched packings.	Renew.	
2. Sliding parts.	1. Scratched or worn oil seals or shafts.	Renew.	
3. Lube oil tube.	1. Loose bolts or scratched.	Retighten or renew.	

6.10 Fuel Oil Leak

Check point	Possible cause	Remedy	Ref. page
1. Fuel tank cock retainer.	1. Loose bolts and nuts, or scratched packings.	Retighten, or renew.	
2. Fuel oil pipe.	1. Loose or scratched bolts.	Retighten, or renew.	
3. Oil reservoir.	1. Defective plunger tightening nuts, loose setbolts, damaged packings, or scratched contact surfaces.	Retighten, or renew.	23

6.11 Water Leak

Check point	Possible cause	Remedy	Ref. page
1. Rocker cover	1. Loose bolts and nuts.	Retighten.	
	2. Damaged packings.	Renew.	
2. Cylinder head.	1. Crack caused by freezing.	Renew.	24
	2. Loose bolts.	Retighten.	
	3. Damaged gaskets.	Renew.	
3. Cylinder body.	1. Crack caused by freezing.	Renew.	
4. Inside of crank-case.	1. Scratched liner packing.	Renew.	

6.12 Cooling Water Failure

Check point	Possible cause	Remedy	Ref. page
1. Kingston cock.	1. Dirty mouth.	Clean.	
	2. Cock in closed position.	Open cock.	
2. Cooling water pipe flange.	1. Scratched packings.	Renew.	22
	2. Loose tightening parts.	Retighten.	22
3. Pump drive V belt.	1. Slack belt.	Tighten. Adjust finger-depressed deflexion to 5-7 mm. 	
4. Cooling water pump.	1. Scratched or worn impeller.	Renew.	22

6.13 Clutch Slip

Check point	Possible cause	Remedy	Ref. page
1. Friction disc.	1. Worn disc.	Renew if total wear on both sides exceeds 2 mm.	43
2. Spring.	1. Weakened or broken.	Renew.	

7. WEAR LIMIT OF EACH MAIN PART

Description		YSE8		YSE12		
		std. dim., mm	wear limit, mm	std. dim., mm	wear limit, mm	
Clear Limitance	Clearance between cylinder liner and piston	0.109	0.36	0.208	0.43	
	Clearance between piston pin and piston pin metal	0.0375	0.30	0.0375	0.30	
	Clearance between crankpin and crankpin metal (see note)	0.036	0.14	0.036	0.17	
	Clearance between crankshaft journal and crank metal	Flywheel side	0.057	0.17	0.059	0.18
		Gear case side	0.07	0.16	0.068	0.21
	Clearance between intake/exhaust valve and valve guide	0.0525	0.3	0.0525	0.3	
Piston ring end clearance	0.3	1.5	0.4	1.5		
Wear Limitance	Cylinder liner top I.D. (over size)	75	+0.30	85	+0.34	
	Piston skirt O.D.	75	-0.23	85	-0.26	
	Piston pin O.D.	23	-0.10	28	-0.11	
	Piston pin metal I.D.	23	+0.10	28	+0.11	
	Crankshaft pin O.D.	42	-0.13	46	-0.14	
	Crankshaft journal O.D.	44	-0.13	52	-0.16	
	Crankpin metal I.D.	42	+0.11	46	+0.12	
	Main bearing metal I.D.	44	+0.11	52	+0.13	
	Top piston ring (chrome-plated)	Breadth	2.0	-0.15	2.5	-0.15
		Thickness	3.3	-0.33	3.7	-0.37
	2nd & 3rd piston rings	Breadth	2.0	-0.15	2.5	-0.15
		Thickness	3.3	-0.33	3.7	-0.37
	Oil ring	Breadth	4.0	-0.15	4.0	-0.15
		Thickness	3.3	-0.33	3.7	-0.37
Intake/exhaust valve spring	Free length	36.5	-1.5 to -2.0	39.5	-1.5 to -2.0	

Models		YSE8		YSE12	
Max. permissible diameter of ground crankshaft	Pin	41.5 φ	-0.025 -0.044	45.5 φ	-0.017 -0.048
	Journal	43.5 φ	-0.035 -0.050	51.5 φ	-0.017 -0.048

8. INSPECTION AND SERVICING OF MAIN PARTS

8.1 Fuel Injection Pump and Nozzle

Both the fuel injection pump and the fuel injection valve (nozzle) are super-high precision finished to atomize fuel oil at an elevated pressure so it can be intimately mixed with air.

Care should, therefore, be taken that they do not get dirty or scratched during disassembly and reassembly. And it is important that they are washed in clear cleaning oil before reassembly.

8.1.1 Fuel injection pump

Disassembled Pump

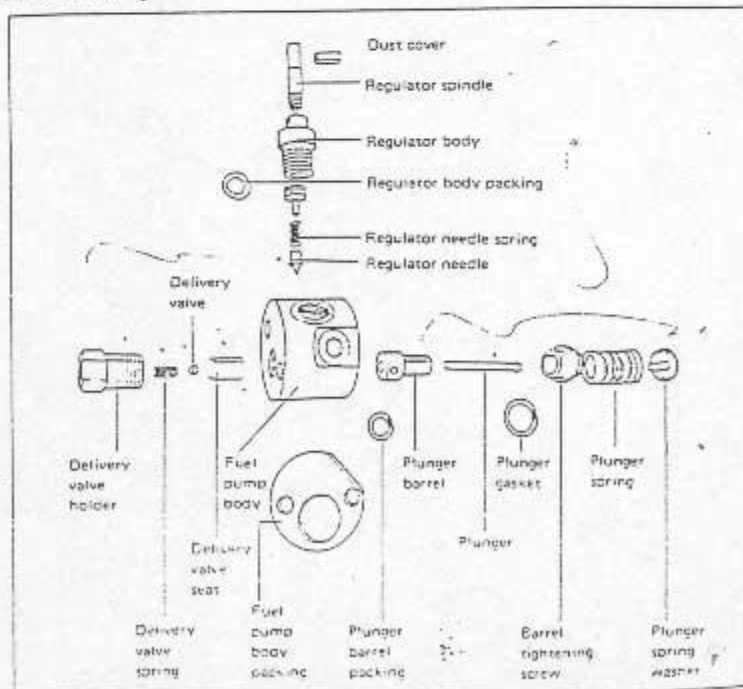

Disassembly

- 1) Remove the pump adjusting lever.
- 2) Remove the delivery valve holder, taking care not to drop the delivery valve (ball).
- 3) Remove the regulator body, taking care not to drop the regulator needle.
- 4) Remove the fuel injection pump body, taking care not to drop the spring and the spring washer.
- 5) Remove the plunger and the plunger barrel. Attach copper sheet to the vise or wind waste cloth on the body, and vise; then remove the barrel tightening screws, using an offset wrench (double head wrench).

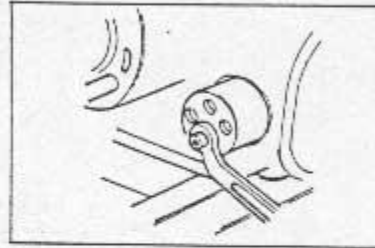

Checking & Servicing

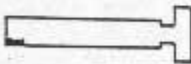
Check point	Remedy	Part code		
		YSE8	YSE12	
Dust, scratches, wear on delivery valve seat and ball.	1. Clean if dusty. 2. Renew if scratched or worn.	Delivery valve assembly	101300-51300	
		Remark:	Common to all models.	
Dust, scratches, wear on regulator needle.	1. Clean if dusty. 2. Renew if scratched or worn.  Stepped wear	Regulator needle	171590-51420	
		Remark:	Common to all models.	
Scratches or wear on plunger (plunger barrel)	1. Renew if scratched or worn.  Wear on plunger end Note: Renew gasket and copper packing together with plunger.	Plunger assembly	104200-51100	102700-51100
		Remark:	Also for TS60	Also for TS105
		Gasket:	172100-51290	
		Copper packing:	172100-51190	
		(Common to all models.)		

Reassembly

1) Tighten the plunger assembly.
Check that the plunger moves lightly while tightening it gradually by use of an offset wrench.

2) Place the spring and the spring washer.

3) Attach the pump body to the engine.

4) Tighten the regulator, with the regulator body turned counter-clockwise to the degree within which it does not come off. Check that the regulator spindle moves lightly.

5) Tighten the delivery valve.

Note: This completes the reassembly; however, air venting of fuel injection pump and adjustment of governor lever are still necessary for engine start-up.

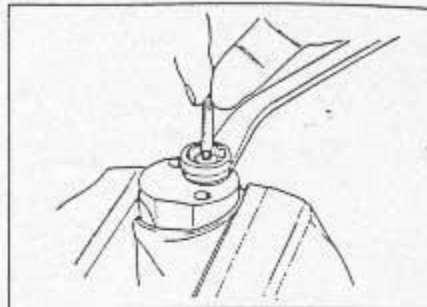

8.1.2 Fuel injection valve (nozzle)

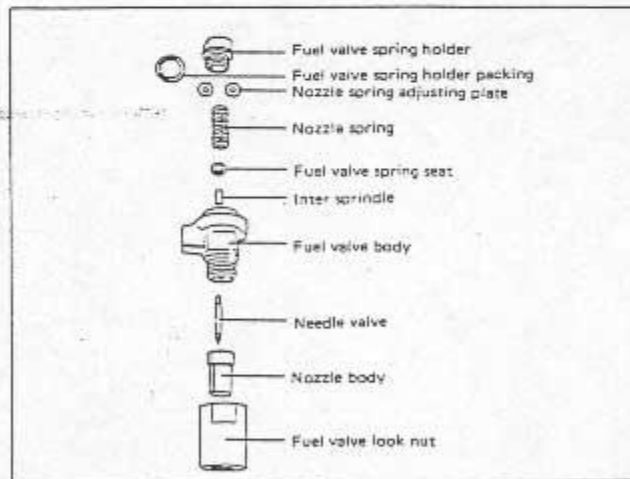

Disassembly

- 1) Detach the fuel injection valve.
- 2) Remove the fuel injection valve lock nut.
- 3) Remove the nozzle valve assembly.

If it is difficult to take out the nozzle body, drive it out by hammering the pipe (see fig.). Do not strike with a driver or the like, for the valve tip might be damaged.

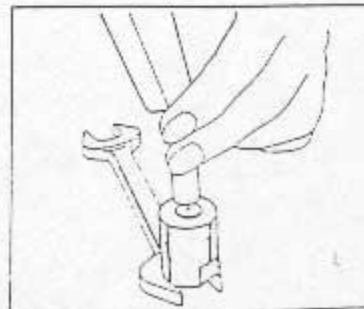

- 4) Take off the fuel injection valve spring holder, taking care not to drop the nozzle spring adjusting plates.

Checking & Servicing

Check point	Remedy	Part code	
		YSE8	YSE12
Nozzle valve. Dusty, stuck, scratched or worn.	1. Clean if dusty. 2. Clean or renew if stuck. 3. Renew if scratched. 4. Renew if worn.	Nozzle valve	
		172100-53000	
		Remark:	Common to all models.

Reassembly

- 1) Attach the inter spindle, spring seat, nozzle spring, adjusting plate, packing, and nozzle spring holder to the fuel injection valve body. Be sure of the spring side of the spring seat, and do not drop the spring adjusting plates.
- 2) Attach the nozzle valve and the nozzle body to the fuel injection valve body.
- 3) Vise the fuel injection valve and tighten various parts.

Verification

After completion of the reassembly, verify that the injection pressure and the spray from are normal or as rated. A nozzle tester simplifies the verification, but if it's not available, fit the fuel injection valve and swing the V pulley of the power take-off shaft to left and right.

Note: Air venting is necessary.

Check point	Judging criterion & remedy	Part code	
		YSE8	YSE12
1. Injection pressure not normal.	1. Judgement using nozzle tester. 2. Judgement without using nozzle tester. (Low pressure: large fuel particle size, or bad exhaust color.). High pressure: small fuel particle size, or knocking. Adjust to 160 kg/cm ² . * Adjusting plate thickness and pressures	Nozzle spring adjusting plate	
		110250-53150	
		Note:	Sold in sets.

2. Spray form not normal.	0.1 mm approximately	7 kg/cm ²
	0.2 mm "	14 kg/cm ²
	0.3 mm "	21 kg/cm ²
	0.5 mm "	35 kg/cm ²

Normal spray angle



Abnormal spray form

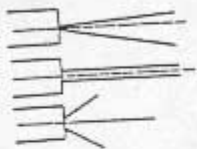

Check the injection pressure and clean or renew nozzle valve.

• 8.1.3 Air venting

The fuel injection system includes the fuel tank, the fuel injection pump, the fuel injection pipe and the fuel injection nozzle.

Air contained in this fuel injection system prevents fuel injection.

In case of fuel failure and when the fuel injection pump is disassembled, air enters the fuel injection system.

Purge the system of air.

Air Venting Procedure

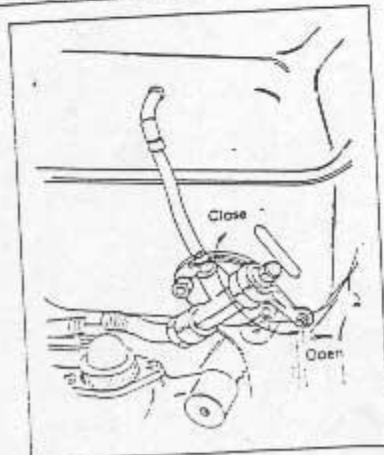

- 1) Place the fuel cock in the open position.

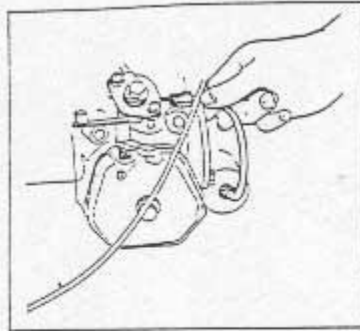

2) Loosen the nipples at both ends of the injection pipe, remove the injection pipe, and place the speed change lever in LOW position.

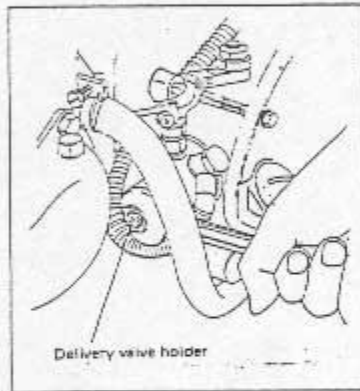

3) Loosen the delivery valve holder (by about two turns), and when bubble-free fuel comes out, securely tighten the delivery valve holder, and then, after attaching the injection pipe, securely tighten the fuel pump side nipple.

4) Confirm if fuel leak out of the nut of the fuel injection valve side, and then tighten securely the nut.

3.2 Cooling Water Pump.

The YSE type cooling water pump, of the rotary type, contains a rubber impeller; it can feed a sufficient quantity of cooling water to all the parts at high speed as well as at low speed.

Disassembled Cooling Water Pump

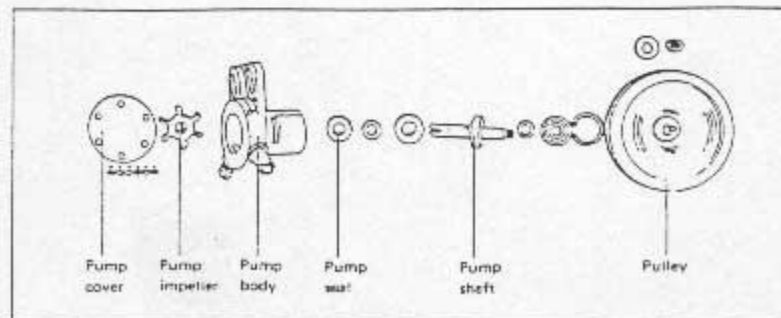

Disassembly

- 1) Detach the pump assembly from the engine.
- 2) Remove the pump drive V. pulley and key.
- 3) Remove the bearing snap ring.
- 4) Take off the pump cover.
- 5) Drive out the drive shaft by hammering with copper hammer from the impeller side to the pulley side. (It comes off with the bearing.)
- 6) Remove the rubber impeller.
- 7) Draw out the seal from the pump body.
- 8) Remove two bearings, one nylon packing and one rubber seal from the drive shaft.

Checking & Servicing

Check point	Remedy	Part code	
Scratches or wear on impeller.	Renew if scratched.		YSE8 YSE12
	Renew if the gap between impeller and pump body side exceeds 0.5 mm.	Impeller	104211-42070
Scratches of wear on pump body and cover surfaces over which impeller slides.	Renew if scratched or worn.		YSE8 YSE12
		Pump body	104211-42010
		Pump body cover	104211-42080
Scratches or wear on pump seal.	Renew if scratched or worn.		YSE8 YSE12
		Pump seal	104211-42100
Wear or rust on bearing.	Renew if worn or rusty.		YSE8 YSE12
		Bearing (6200ZZ)	24107-062004

Reassembly

- 1) Insert the cooling water seal into the pump body and apply grease to the seal.
- 2) Place two bearings, distance piece nylon packing, and rubber seal upon the drive shaft, place the assembly into the pump body, and then place the snap ring.

- 3) With it set in the groove on the drive shaft, insert the impeller into the pump body. The drive shaft rotates counter-clockwise when viewed from the pulley side. Be sure the impeller is inserted correctly.
- 4) Place the pump body cover.
- 5) Attach the key and the V pulley, place the lock washer and tighten the nut.
- 6) Bend the lock washer.
- 7) Attach the pump assembly to the engine and tighten the V belt.

Adjust the finger-depressed deflection to 5-7 mm.



Verification

Attach the pump assembly to the engine and operate it to verify that its discharge is as specified below:

YSE8	500 lit. /hr.	Pump shaft speed 2000 rpm (Crankshaft speed 3200 rpm)
YSE12	460 lit. /hr.	Pump shaft speed 1900 rpm (Crankshaft speed 3000 rpm)

(Note) If operated without water, the rubber impeller will burn. Never operate without water!

8.3 Cylinder Head

The cylinder head is a gasket type: the valve guides and the cylinder head are in one piece, and a large diameter intake valve is used for greater suction efficiency. The intake and exhaust valves are of the totally enclosed and supplied lube oil with forced circulation lubrication system.

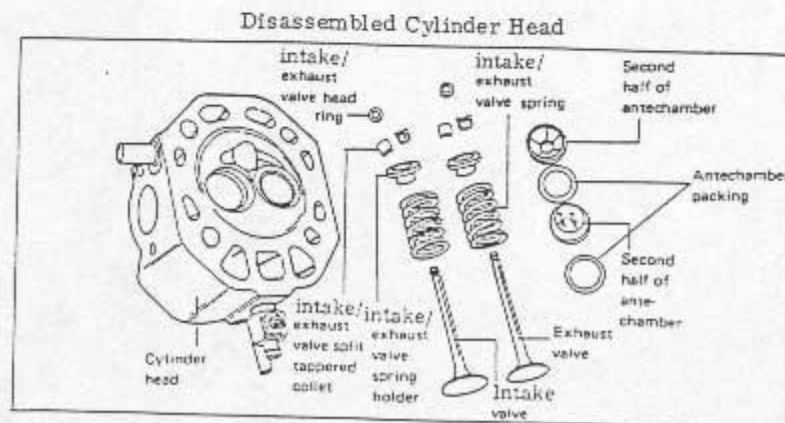

Disassembly

- 1) Detach the cylinder head from the engine, remove thoroughly carbon from combustion surfaces of the cylinder head and from the internal surfaces of the pre-combustion chamber, and then inspect and service the valves.
- 2) Remove the split taper collets by pressing each spring holder with spanner. They will come off toward the combustion chamber.

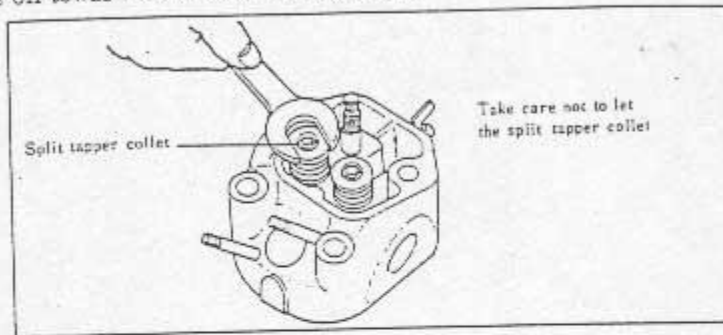

Checking & Servicing

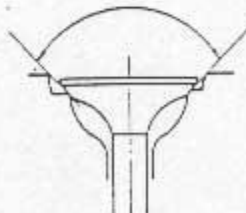
Check point	Remedy	Part code										
		YSE8	YSE12									
Scratches or wear on intake/exhaust valve seating surface. 	Renew if stepped wear or deep scratches. Fit if poor fitting or shallow scratches. (Refer to next column.) Note: Seat width should be less than 2 mm.	<table border="1"> <tr> <td></td> <td>YSE8</td> <td>YSE12</td> </tr> <tr> <td>Intake valve</td> <td>104211-11100</td> <td>104511-11100</td> </tr> <tr> <td>Exhaust valve</td> <td>104211-11100</td> <td>104511-11110</td> </tr> </table>		YSE8	YSE12	Intake valve	104211-11100	104511-11100	Exhaust valve	104211-11100	104511-11110	
	YSE8	YSE12										
Intake valve	104211-11100	104511-11100										
Exhaust valve	104211-11100	104511-11110										
Scratches or wear on cylinder head valve seat.	Lap if scratched or worn to a broader width than specified. Lapping method (If heavily worn or scratched, correct with a seat cutter.)  <ol style="list-style-type: none"> 1. Lap till scratches are gone with coarse compound, then with fine compound. For finishing, use oil. 2. Wash off the lapping compound. 3. Apply red lead to the seat and check fitting after the lapping operation. 4. After that, be sure to apply oil to seat. 											

Wear on valve guides and valves.	Renew cylinder head or valve if worn.		YSE8	YSE12
		Intake valve	104211 -11100	104511 -11100
		Exhaust valve	104211 -11110	104511 -11110
		Cylinder head	104211 -11010	104507 -11010

Reassembly

- 1) Insert the intake and exhaust valves into the cylinder head, and secure each valve spring stop with a spanner placed upon the valve spring holder.
- 2) Check and renew (if necessary) the gasket.
- 3) Clamp the cylinder head evenly in the diagonal direction.

Cylinder head lock nut tightening torque.
kg-m

	YSE8	YSE12
Tightening torque	8.8	12.4

8.4 Piston and Connecting Rod Assembly

The piston of high silicon featuring a low expansion coefficient and outstanding resistance to heavy load is oval shaped externally. The stamp forged connecting rod has piston pin metal at its smaller end and crankpin metal at its larger end. The piston rings are composed of three pressure rings and one oil ring.

Piston and Connecting Rod Assembly
As Disassembled

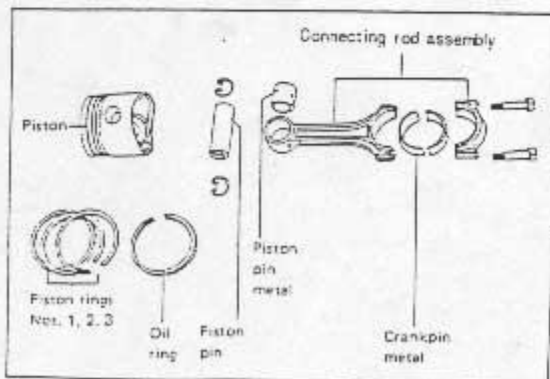

Connecting rod lock nut tightening torque.

	kg-m	
	YSE8	YSE12
Tightening torque	3	3.5

Disassembly

1) Ring removal

- 1-1 Make two 4 cm-dia. rings of tag wire.
- 1-2 Slightly pull each ring and open with the wires placed at its ends and remove. Excessive opening will cause ring breakage.
- 1-3 After removal of all the rings, clean the ring grooves.

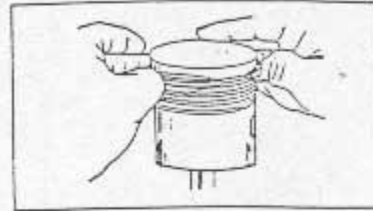

2) Disassembly of piston and connecting rod

The piston and the connecting rod are connected to each other through the piston pin. The piston pin hole has a little tightening allowance when cold. It is therefore necessary to heat the piston when it is to be taken out or inserted.

- 2-1 Remove two piston pin stop rings.
- 2-2 Heat the piston pin for 15 min. in oil at oil temperature of 80° C.

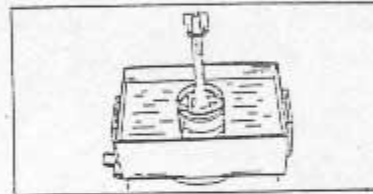

- 2-3 Take out the piston pin using the exclusive tool.

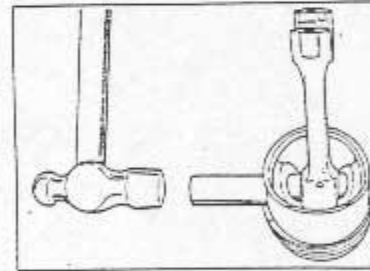



Checking & Servicing

Note: It is recommended that parts be renewed at max. allowable values.

Check point	Remedy				Part code			
		YSE8		YSE12		YSE8	YSE12	
		nom.	max.	nom.	max.			
Wear on ring. Measure their breadths and thicknesses using a micrometer.	No. 1 ring chrome-plated	B	2.0	-0.15	2.5	-0.15	No. 1 ring 104200 22110	104500 22110
		T	3.3	-0.33	3.7	-0.37		
	No. 2 & No. 3 rings	B	2.0	-0.15	2.5	-0.15	No. 2 & No. 3 rings 104200 22100	103458 22100
		T	3.3	-0.33	3.7	-0.37		
	Oil ring	B	4.0	-0.15	4.0	-0.15	Oil ring 104200 22200	103458 22200
		T	3.3	-0.33	3.7	-0.37		

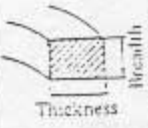
Renew if wear exceeds max. allowable value.

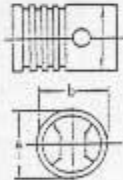
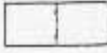

Check point	Remedy				Part code																			
	YSE8		YSE12		YSE8	YSE12																		
Clearance between ring and ring groove. Measure using a clearance gauge.																								
	nom.	max.	nom.	max.	Piston																			
Clearance between ring and ring groove				0.037	0.30	0.037	0.30																	
Renew if clearance exceeds max. allowable value.																								
Note: Nom. and max. in the above table represent nominal values in mm and maximum allowable values in mm, respectively.																								
Ring end gap. Insert each ring in liner skirt and measure its end gap using a clearance gauge.	Standard gap YSE8 0.2 to 0.4 mm YSE12 0.3 to 0.5 mm (Renew if the gap exceeds 1.5 mm.)				(See above.)																			
																								
Wear on piston. Measure dia. of skirt using a micrometer.	<table border="1"> <thead> <tr> <th colspan="2">YSE8</th> <th colspan="2">YSE12</th> </tr> <tr> <th>std. diam, mm</th> <th>max. allowable wear, mm</th> <th>std. diam, mm</th> <th>max. allowable wear, mm</th> </tr> </thead> <tbody> <tr> <td>75 φ</td> <td>-0.23</td> <td>85 φ</td> <td>-0.26</td> </tr> </tbody> </table>				YSE8		YSE12		std. diam, mm	max. allowable wear, mm	std. diam, mm	max. allowable wear, mm	75 φ	-0.23	85 φ	-0.26	(Ditto)							
YSE8		YSE12																						
std. diam, mm	max. allowable wear, mm	std. diam, mm	max. allowable wear, mm																					
75 φ	-0.23	85 φ	-0.26																					
																								
Wear on piston pin. Measure O.D. of piston pin using a micrometer.	<table border="1"> <thead> <tr> <th colspan="2">YSE8</th> <th colspan="2">YSE12</th> </tr> <tr> <th>std. diam, mm</th> <th>max. allowable wear, mm</th> <th>std. diam, mm</th> <th>max. allowable wear, mm</th> </tr> </thead> <tbody> <tr> <td>23 φ</td> <td>-0.10</td> <td>28 φ</td> <td>-0.11</td> </tr> </tbody> </table>				YSE8		YSE12		std. diam, mm	max. allowable wear, mm	std. diam, mm	max. allowable wear, mm	23 φ	-0.10	28 φ	-0.11	<table border="1"> <thead> <tr> <th></th> <th>YSE8</th> <th>YSE12</th> </tr> </thead> <tbody> <tr> <td>Piston pin</td> <td>104200 -22300</td> <td>103438 -22300</td> </tr> </tbody> </table>			YSE8	YSE12	Piston pin	104200 -22300	103438 -22300
YSE8		YSE12																						
std. diam, mm	max. allowable wear, mm	std. diam, mm	max. allowable wear, mm																					
23 φ	-0.10	28 φ	-0.11																					
	YSE8	YSE12																						
Piston pin	104200 -22300	103438 -22300																						
Renew if wear exceeds the maximum allowable value.				24.74 ←																				
																								

Check point	Remedy				Part code		
	YSE8		YSE12			YSE8	YSE12
Wear on piston pin metal. Measure using a cylinder gauge.	std. diam, mm	max. allowable wear, mm	std. diam, mm	max. allowable wear, mm	Piston pin metal	104200 -23100	103438 -23100
	42 φ	+0.10	28 φ	+0.11			
	Renew if wear exceeds the maximum allowable value.						
Wear on crankpin metal. Measure using a cylinder gauge.	std. diam, mm	max. allowable wear, mm	std. diam, mm	max. allowable wear, mm	Crankpin metal	104200 -23340	103338 -23500
	42 φ	+0.11	46 φ	+0.12			
	Renew if wear exceeds the maximum allowable value.						

Cross-sectional views of piston rings:

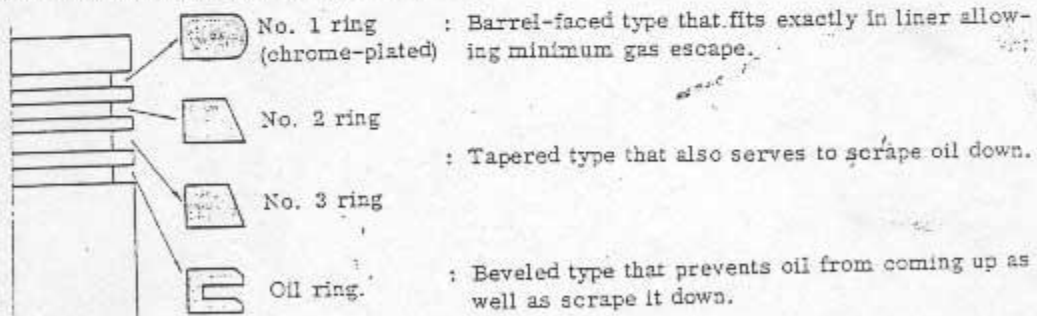

Reassembly

1) Reassembly of piston rings

- 1.1 Clean piston ring grooves before ring placement, preferably with an old ring (broken).

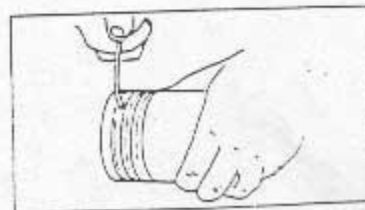

- 1.2 Place rings upon piston, ring marks head side.

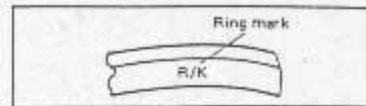

- 1.3 Check rings move lightly in the grooves.
- 1.4 Be sure that ends of one ring are 90° apart from those of neighboring ring or other rings.

2) Reassembly of piston, connecting rod

- 2.1 Place a piston pin snap ring upon the piston only one side.
- 2.2 Check that the piston pin enters lightly into the piston pin metal of the connecting rod.
- 2.3 Heat the piston pin for 15 min. in oil at oil temperature of about 80° C. Use either light oil or heavy oil.
- 2.4 Insert the connecting rod into the piston, then insert the piston pin, from the side without piston pin snap ring.
DO NOT INSERT IT BY FORCE.
- 2.5 Place the other piston pin stop ring.
- 2.6 Check that both the piston and the connecting rod move lightly. If they do not move lightly, seizure will result.



8.5 Cylinder Liner

The cylinder liner is a wet type, made of special cast iron and coated with rust-preventing paint.

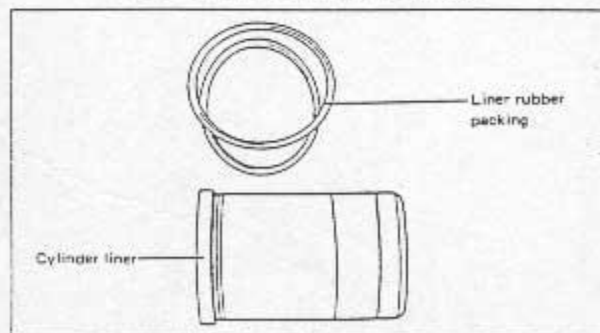
Cylinder Liner As Disassembled

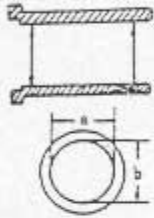

Note: It is recommended that parts be renewed at max. allowable values listed in the following table.

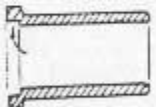
Check point	Remedy				Part code		
	YSE8		YSE12			YSE8	YSE12
Scratches or wear on cylinder liner. (1) Measure using a cylinder gauge. 	Nominal inside diam. mm	Max. allowable scratch or wear, mm	Nominal inside diam. mm	Max. allowable scratch or wear, mm	Cylinder liner	104211 -01100	104511 -01100
	75 φ	+0.30	85 φ	+0.34	Liner rubber packing	101204 -01300	103388 -01300
(2) Another simpler method. Insert a new ring into No.1 ring position of liner, then measure the ring end gap using a clearance gauge. Note: The ring inserted should be perpendicular to liner. 	Renew if the gap exceeds 1.0 mm, on both YSE8 and YSE12 models.						
(3) Visual determination 	Renew if observed <u>steps</u> .						

Renewal

- 1) Attach lock nuts to two cylinder head set-bolts positioned symmetrically to each other, and pull out the liner with the liner puller. Drive the nuts till four to five threads come into sight.
- 2) Remove the liner rubber packing.

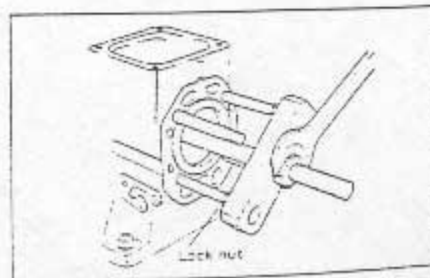

- 3) Remove thoroughly paint and dust from liner setting surfaces, the rubber packing groove, etc.

Reassembly

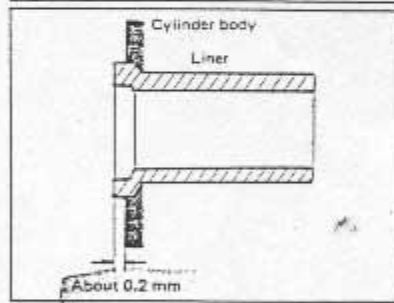
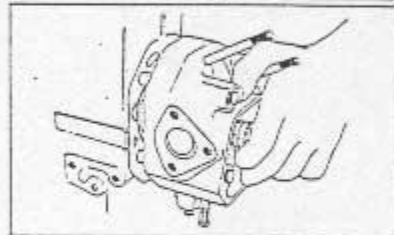
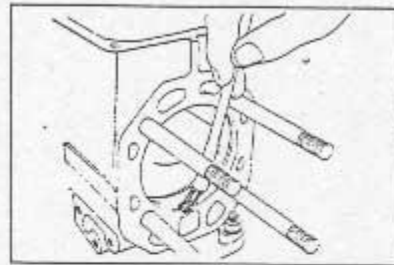

- 1) Place the liner rubber packing correctly.
- 2) Apply white paint to liner setting surfaces (front and rear) as evenly as possible.
- 3) Insert the cylinder liner and tap with the cylinder head.
- 4) Attach head lock nuts to two head setbolts positioned symmetrically to each other, then tighten.
- 5) Check that the liner top is about 0.2 mm projecting from the cylinder body.
- 6) Measure the inside diameter of the liner to check that it is of the same dimension in both *a* and *b* directions.

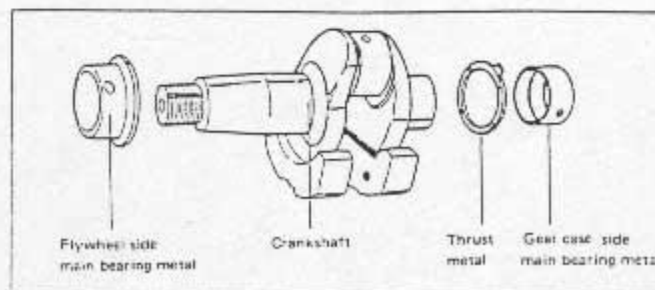

E.5 Crankshaft and Main Bearing Metal

The crankshaft is induction hardened and super-high precision finished. The main bearing metal uses thin back metal on the gear case side and gilled kelmet back metal on the flywheel side.

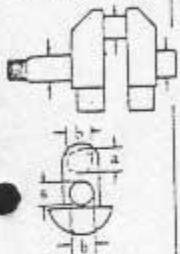
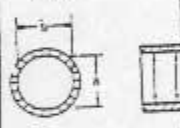

Check point	Remedy				Part code	
	YSE8		YSE12		YSE8	YSE12
Wear on crankshaft. Measure with a micrometer. 	nom. dim., mm	max. allowable wear, mm	nom. dim., mm	max. allowable wear, mm	Crankshaft assembly	704211-21100 / 704511-21100
	Crankpin	42	-0.13	46		
	Journal	44	-0.13	52	-0.16	
	Renew if wear exceeds the maximum allowable value.					
Wear on main bearing metal. Measure with a-cylinder gauge. 	nom. dim., mm	max. allowable wear, mm	nom. dim., mm	max. allowable wear, mm	Gear case side m.b.m.	104200-02100 / 104500-02100
	Main bearing metal	44	+0.11	52		
	Renew if wear exceeds the maximum allowable value.					
Wear on thrust metal. Measure with a micrometer. 	nom. dim., mm	max. allowable wear, mm	nom. dim., mm	max. allowable wear, mm	Thrust metal	104200-02110 / 104500-02110
	Thrust metal	2.5	-0.3	2.5		
	Renew if wear exceeds the maximum allowable value.					

Renewal of Main Bearing Metal

- 1) Drawing-out of gear case side main bearing metal
 - 1.1 Draw out the crankshaft and the governor.

Bearing metal puller

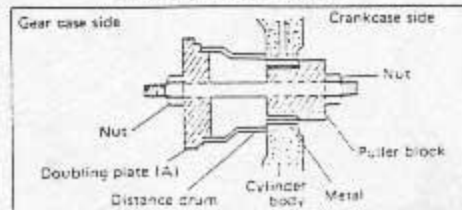

1.2 Mount the bearing metal puller.

1.3 Insert the bearing metal puller into the bearing metal, draw out bearing metal by tightening the puller nut.

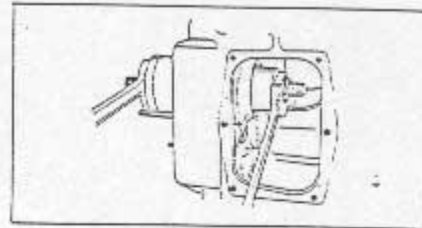

2) Insertion of gear case side main bearing metal

2.1 Clean the bearing metal fitting surface of the cylinder body.

2.2 Reassemble the bearing metal puller for metal insertion.

2.3 Place a new bearing metal upon the bearing metal insertion tool, with the chamfered side of the bearing metal contour facing the cylinder body.

2.4 Insert both the bearing metal insertion tool and the bearing metal into the bearing metal hole from the crankcase side.

2.5 With the oil holes of the cylinder body and of the bearing metal agreeing exactly, tighten the nut till the bearing metal is fully inserted.

2.6 Remove the bearing metal insertion tool, then check that the oil holes agree exactly.

Bearing metal insertion tool

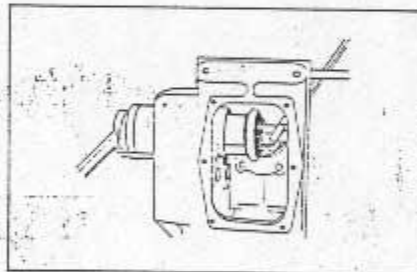
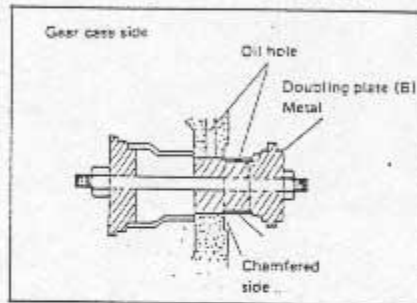

3) Drawing-out of flywheel side main bearing metal

3.1 Remove the oil seal.

3.2 Draw out the bearing metal in the same way as for drawing-out of gear case side main bearing metal, using the bearing metal puller

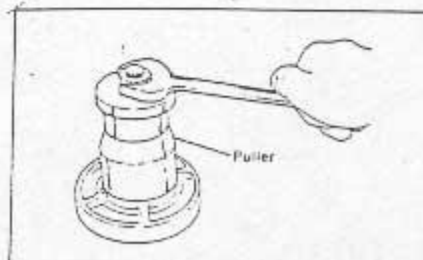

- 4) Insertion of flywheel side main bearing metal
 - 4.1 Clean the bearing metal fitting surface of the cylinder body.
 - 4.2 Mark off a line on which knock pin is to be located.
 - 4.3 Let the marked-off line on the bearing metal meet exactly with the flywheel housing lock groove, and insert the wooden insertion tool into the bearing metal fully with the use of a hammer.
 - 4.4 Remove the insertion tool, and check that the knock pin and the lock groove as well as oil holes agree completely.
 - 4.5 Attach the oil seal.

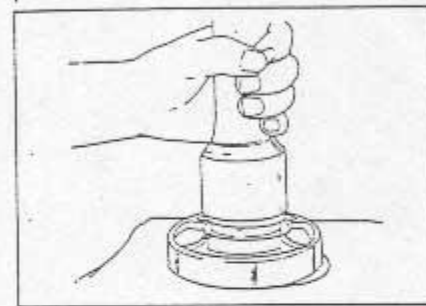
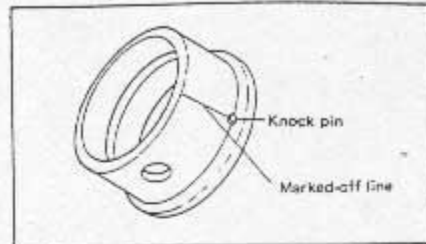

8.7 Electrical Equipment

The electric starter for the YSE series diesel engines, directly coupled to the flywheel housing, starts the engine, in engagement with the ring gear of the flywheel. The generator is driven by the V belt on the power take-off pulley.

WIRE DIAGRAM FOR YSE SERIES

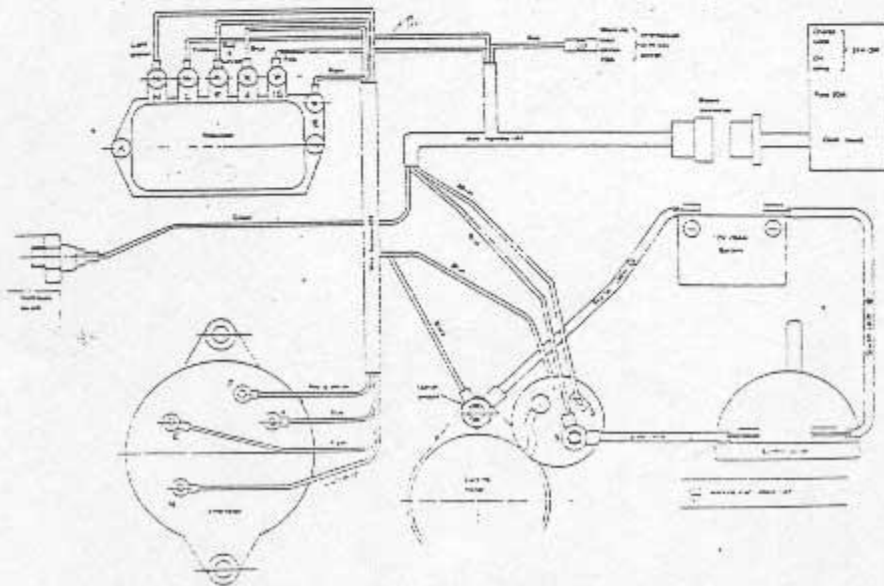

1. The instrument panel can be optionally located within reach of the wire harness.
2. Fully tighten the terminals and apply grease.
3. Recheck after wiring.

(Note) Do not operate the engine with the starter cable removed from the battery, for overheated generator might cause trouble.

8.7.1 Starter

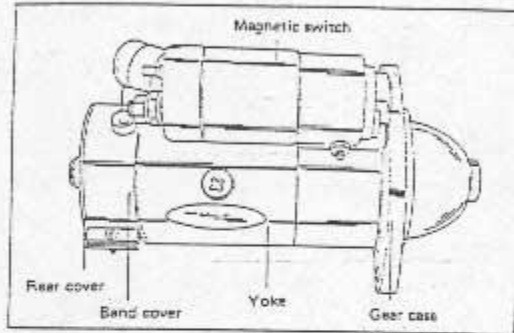

Specifications

	YSE8	YSE12
Model	S114-134	S114-134
Voltage	12V	12V
Output	1.0KW	1.0KW
Gear ratio	114/9 = 12.65	126/9 = 14.0

Disassembly

- 1) Remove the starter from the engine.
- 2) Take off the band cover and clean the four carbon brushes.

Checking & Servicing

Check point	Remedy	Part code						
Brush wear. Measure with vernier calipers. 	<table border="1" style="margin-left: auto; margin-right: auto;"> <thead> <tr> <th></th> <th>Nominal length, mm</th> <th>min. allowable length, mm</th> </tr> </thead> <tbody> <tr> <td>Total length</td> <td>16</td> <td>9.5</td> </tr> </tbody> </table> <p>Renew if the total length is below 9.5 mm.</p>		Nominal length, mm	min. allowable length, mm	Total length	16	9.5	
	Nominal length, mm	min. allowable length, mm						
Total length	16	9.5						
Weakened or broken brush spring.	Renew if weakened or broken.							

Reassembly

- 1) Set the carbon brush and place the band cover.
(Note) Check the (+) and (-) sides of the carbon brush. Also, secure the brush spring.

- 2) After reassembly, conduct a verification test, and then check that its performance is as specified.
- * Whatever question you may have about the starter reassembly, please let us know.

3.7.2 Alternator

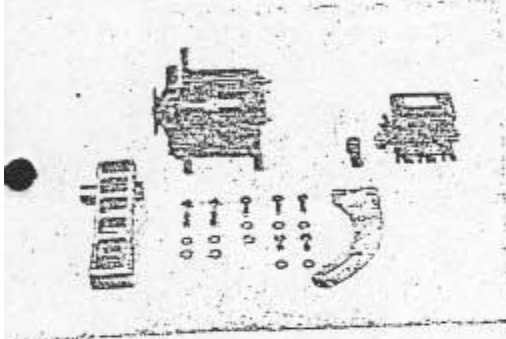

Specifications

Type	Alternator (Tirill type)
Nominal output	12V-25A/5,000 rpm
Earth polarity	(-) side grounded

Checking & Servicing

Check point	Remedy	Part code
Voltage and current	<ol style="list-style-type: none"> Limit voltage: $14 \pm 0.5V$ Charging current: <u>25A</u> or more at 14V/5,000 rpm (Alternator) Measure the charging current when the terminal voltage of the battery is 14V with the resistance load connected in parallel with the battery. Renew the assembly if the above specifications are not satisfied. 	

9. ADJUSTMENTS

9.1 Governor Lever

9.1.1 Adjustment procedure

- (1) Place the regulator remote control lever in "OPERATE" position.

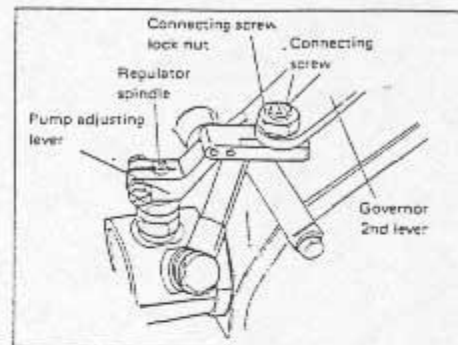

- (2) Turn the punch mark on the connecting screw toward the cylinder perpendicularly to the pump adjusting lever.

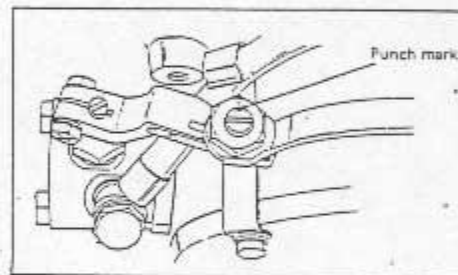
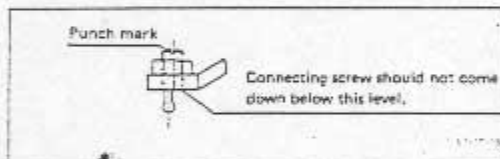

(Note) Drive in the connecting screw till its bottom comes to the top level of the pump adjusting lever.

- (3) Lightly screw in the regulator spindle clockwise.
- (4) Tighten the cross-recessed head screw for the pump adjusting lever, and tighten the lock nut on the other side.
- (5) Turn the connecting screw (punch mark) counter-clockwise by 90°, then tighten the lock nut.

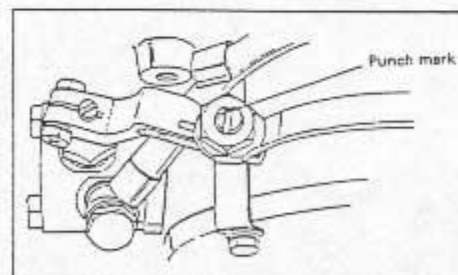

Note: If the pump adjusting lever moves outside when the connecting screw is turned by 90°, go back to step (3). After that, if the governor 2nd lever moves inside, the adjustment is perfect.

- (6) a. Check that when the pump adjusting lever is pushed to the cylinder side, the regulator spindle moves, too.
(Temporary high-speed rotation will result if the engine is started while the spindle does not move.)

- b. After reassembly is completed, check, by turning the handle, that the fuel injection noise is normal.

9.1.2 Readjustment procedure

Although the above steps (1) to (6) will do, of course, the steps stated below may be followed for simplicity's sake.

- (1) Loosen the connecting screw lock nut.
- (2) Turn the connecting screw (punch mark) by 90° from left toward you.
- (3) Tighten the connecting screw lock nut.

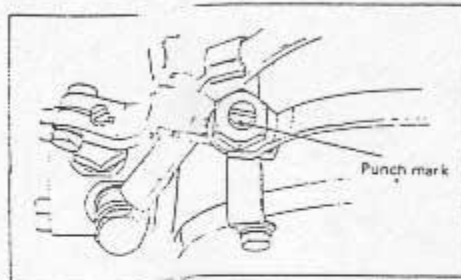

9.2 Intake/Exhaust Valve

9.2.1 Adjustment procedure

- (1) Bring the TD mark on the flywheel to the marked-off line on the flywheel housing.
- Note: Set to the top dead center of compression stroke (TD mark).
- (2) Loosen the valve clearance adjusting screw lock nut.
 - (3) Adjust the clearance to 0.2 mm by means of the valve clearance adjusting screw.

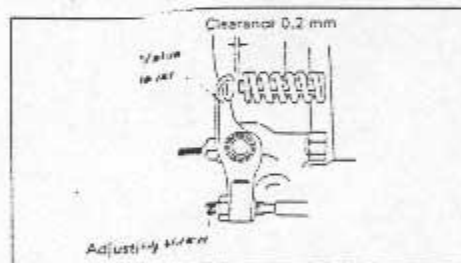

Note: Adjust both suction valve and exhaust valve clearances to 0.2 mm when the engine is cool.

- (4) Fix the adjusting screw using a (-) driver, then tighten the lock nut.



9.3 Fuel Injection Timing

On models YSE8 and YSE12, fuel injection is started at 10° plus or minus 2° before T. D. C.

9.3.1 Checking hints

- (1) Remove the cover of the starter mounting hole. (Remove the starter for electric starting.)

- (2) Set the TD mark of compression stroke on the flywheel to the mark on the flywheel housing.
- (3) Place the accelerator lever in the "OPERATE" position.
- (4) Read out the start position of fuel injection noise by swinging the power take-off pulley to left and right.
- (5) Judge correctly by repeating the step (4) three or four times.

9.3.2 Adjustment procedure

- (1) Detach the fuel injection pump and the pump mount.
- (2) Increase or decrease the number of the fuel injection timing adjustment plates. If the timing is advanced, increase the number of the adjustment plates; delayed, decrease the number.
0.1 mm of plate thickness is equivalent to approximately 2° of time difference.
- (3) Mount the fuel pump mount and the fuel pump.

Note: Check the fuel injection timing.

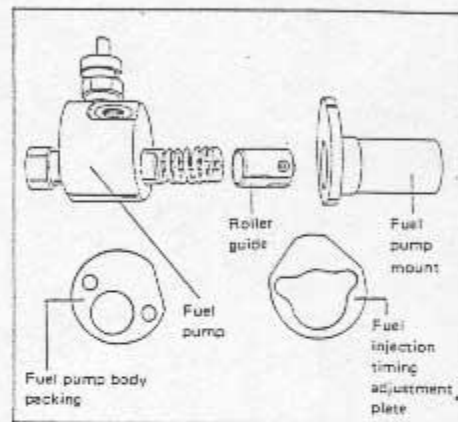

Yanmar YSE manual

Blank page

Yanmar YSE manual

Blank page

10.2.4 Others

Emery paper, emery cloth	White paint	Brush	Waste cloth
--------------------------	-------------	-------	-------------

10.3 Precautions

- (1) Prior to disassembly, refer to the instruction manual and the parts list.
- (2) Use the right tools, and take care not to scratch the parts or wound yourself.
- (3) When driving out a shaft or other parts, use a protective bar or a copper hammer.
- (4) Place in order the disassembled parts.
- (5) Check 0 marks on coupling, cam gear and crank gear.
- (6) Make proper provision for locking parts which give incidental rotation when other parts are moved.
- (7) Take care not to scratch oil seals and other parts.
- (8) For total disassembly, discharge beforehand lube oil, cooling water, and fuel from the crankcase, and from the gear case.

10.4 Clutch Disassembly Procedure

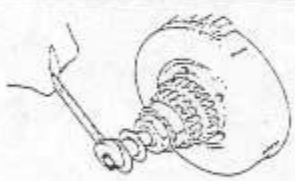
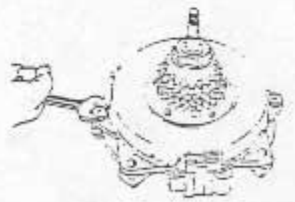
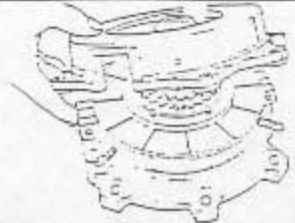
Step	Procedure	Tools	Illustration
1	Remove one cotter pin, one slotted nut and one woodruff key for shifter.	Pinchers Spanner 17	
2	Remove the two setbolts for clutch housings A and B, and then two spring washers by hand.	Spanner 17	
3	Detach one slide shaft.		
4.	Pry separate the housing B from the housing A. Note: Positioning claws and springs leap out. Remove three claws and three springs.	(-) Drive	

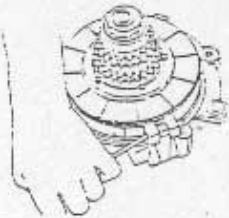
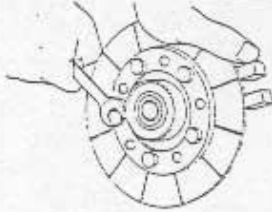
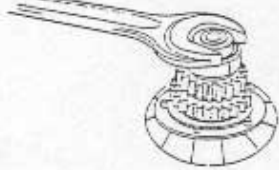
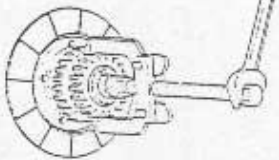
Step	Procedure	Tools	Illustration
5	Drive out two connecting spectacle link pins, from the holding friction the holding friction disc side.	Hammer protective bar	
6.	Detach the clutch housing A assembly.		
7.	Detach one piece of wire and five bolts from the ahead side.	Pinchers Spanner 13	
8	Remove one ahead friction disc and one friction disc keep plate.		
9	Remove one holding friction disc.		
10	Remove one ahead shaft lock nut. Note: Completely flatten the lock washer. Remove one lock washer.	(-) Drive Hammer Spanner 36	
11	Pull out one bearing from the clutch case rear box side.	Bearing puller	
12	Pull out one small ahead gear, one key.	Gear puller	

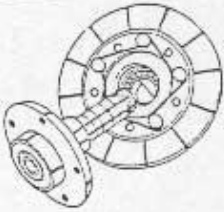
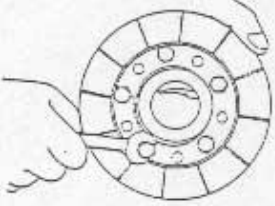
Step	Procedure	Tools	Illustration
13	Remove one ahead shaft (with bearing).		
14	Remove one piece of wire and five bolts to detach one friction disc assembly and one bearing from the astern gear.		
15	Pull out one ahead shaft bearing (housing A side).	Bearing puller	

Disassembled Clutch

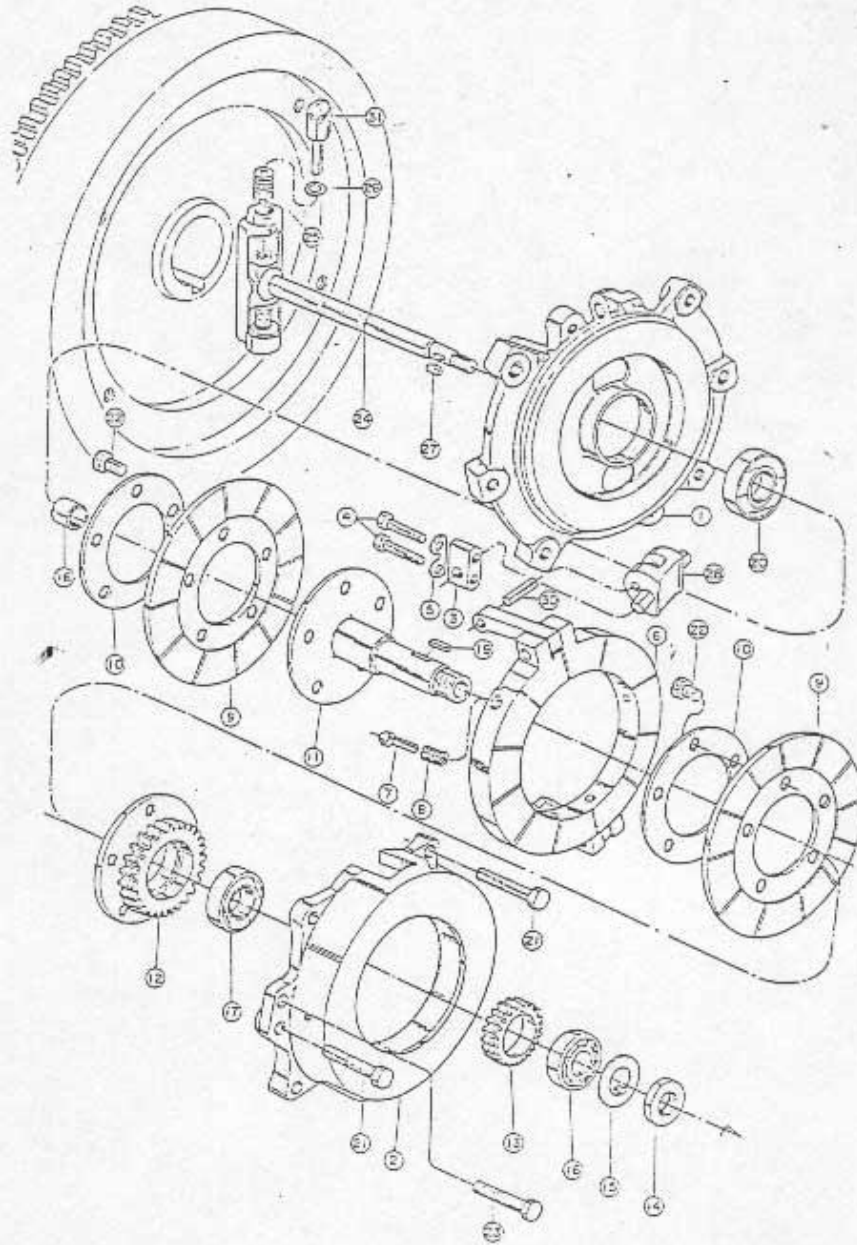

ITEM	PART NAME	ITEM	PART NAME
1	Housing A	17	Ball bearing 6005
2	Housing B	18	Shifting shaft bush
3	Set piece for V lever	19	Feather key 7 × 20
4	Setbolt for V lever set piece	20	Ball bearing 6205 ZZ
5	Washer	21	Bolt M10 × 45
6	Friction disc	22	Setbolt and wire for keep plate
7	Friction disc claw	23	Bolt M10 × 30
8	Friction disc claw spring	24	Shifting shaft
9	Friction disc keep plate	25	Spring
10	Keep plate washer	26	Spring holder
11	Ahead shaft	27	Key 4 × 13
12	Reversing gear	28	V lever
13	Small ahead gear	29	Link
14	Ahead shaft lock nut	30	Link pin
15	Washer	31	V lever holder
16	Ball bearing 6205		

11. REASSEMBLY

11.1 Precautions

- 1) Clean parts thoroughly in oil.
- 2) Use the right tools and assemble the engine faultlessly.
- 3) Apply lube oil to rotary and-sliding parts.
- 4) Use new packings, cotter pins and lock washers.
- 5) Make sub-assemblies beforehand.
- 6) Correct or renew scratched or worn parts beforehand.
- 7) Take care to evenly tighten bolts and nuts located symmetrically to each other.
- 8) Let the setting marks on the crank gear and the coupling agree exactly.
- 9) Securely attach the cotter pins, lock washers, wire, etc.
- 10) Proceed with the assembly checking that the rotary and sliding parts move smoothly.

12. STERN ARRANGEMENT

The following standard stern arrangements are prepared for use with the Yanmar diesel engines YSE8(G) and YSE12(G). Select the optimum model for your intended use and Hull.

1. Propeller Shaft

Direct-coupled propeller shafts.

Select the optimum model for the engine output and the ship size. When coupling it to the propeller shaft of the engine, be sure to center it in correct alignment with the latter.

Standard Stern Arrangement

Model	Propeller shaft, rpm	Propeller		Propeller shaft		Stern tube	
		diam. in.	pitch. in.	diam. mm	length. mm	B diam. mm	A length mm
YSE8	1127	14	9	22	1800	46	400
	1332	13	8 1/2				
	1639	12	7 1/2				
YSE8G	751	18	12	25	2000	50	500
	885	16 1/2	11				
	1093	15	10				
YSE12	1113	15	10	25	2000	50	500
	1316	14	9				
	1518	13	8 1/2				
YSE12G	718	19	15	28	2400	56	650
	849	18	13				
	980	17	12				

Note: Standard propeller is of integrated 3-blades type. It is made of manganese bronze, having an area ratio of 0.36.

